

Partition System 2300

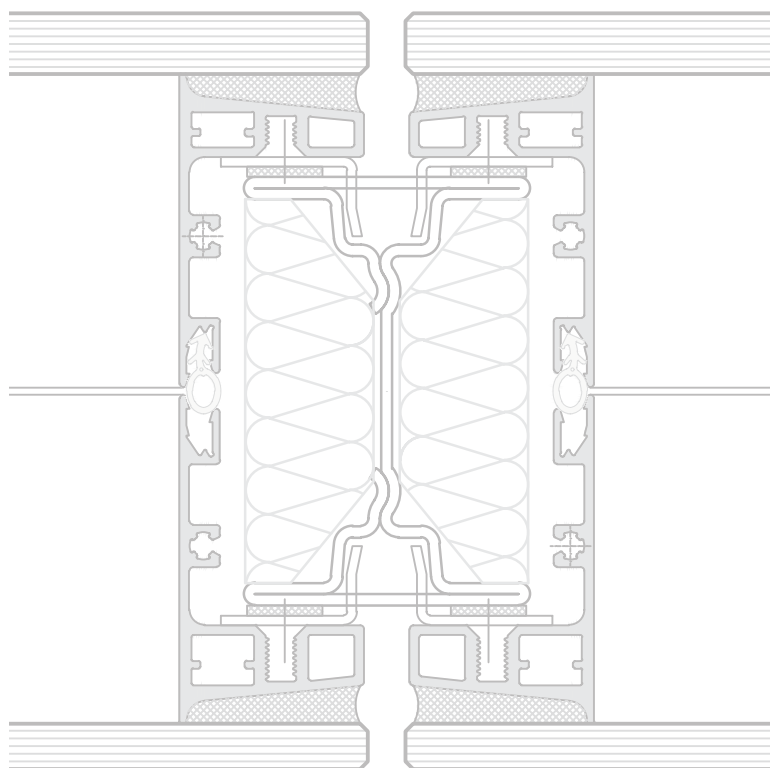

System 2300

Design with mullion - flush bonded glass
100 mm wall thickness
125 mm wall thickness

Flush-bonded glazed wall without a visible frame which creates open and transparent space. The innovative partition wall System 2300 is the flush bonded glazed version of the System 2000 family. It is characterised by its plain surface and the mirroring effect of its glazing in combination with highly efficient sound insulation and fire prevention.

The basis for this highly flexible partition wall system with modular panel design for walls is the patented Strähle mullion with integrated suspension for panels, glazing and accessory systems. The glazing is manufactured as a complete element to be suspended from the mullion on both sides.

Door elements are available in different variations such as solid doors, aluminium framed or flush bonded doors. In the case of exceptionally high rooms or if higher acoustic performance is required, it is recommended to utilise a variation of System 2300 partition wall which is 125 mm thickness.

Design

Design with mullion

Options

Flush bonded glazing without visible frame made of toughened safety glass or acoustic laminated glass

Element types

Fully glazed, clerestory, balustrade

Surfaces

Glass wall (toughened safety glass / acoustic laminated glass)

Solid wall (melamine, veneered, HPL or lacquered)

Bonding

Light grey (black and white upon request)

Wall thickness

100 / 125 mm

Visible width

Glass wall: frame width 2 x 25 mm / 2 x 35 mm

Solid wall: 5 mm joint

Sound insulation

Glass wall: up to Rwp 54 dB

Solid wall: up to Rwp 56 dB

Fire prevention

Glass wall: various - further details upon request

Solid wall: various - further details upon request

Accessories

Acoustic absorbers, blinds, climate control elements, accessory systems



Flush bonded glazing

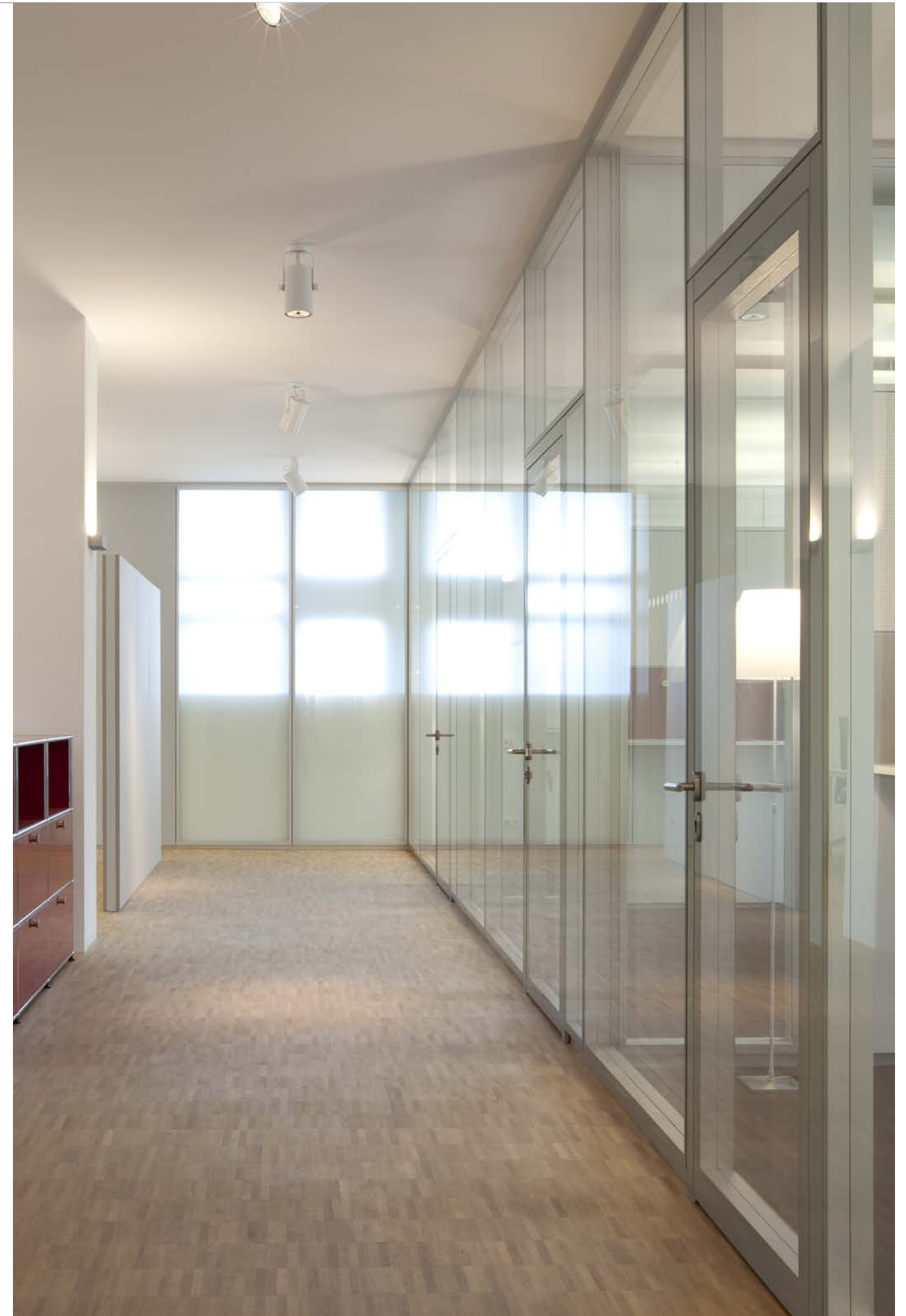
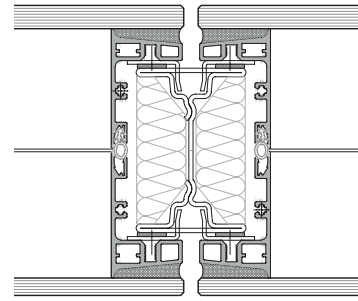

Corridor wall with flush bonded door

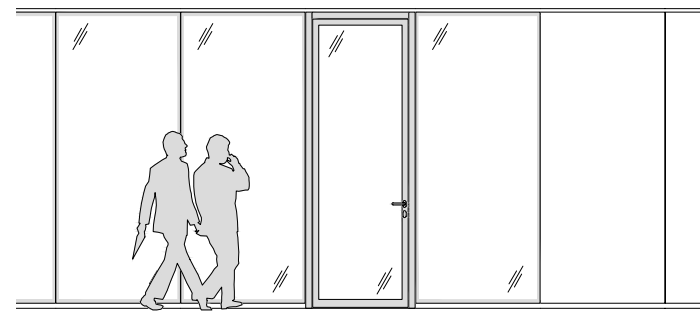

Cross wall

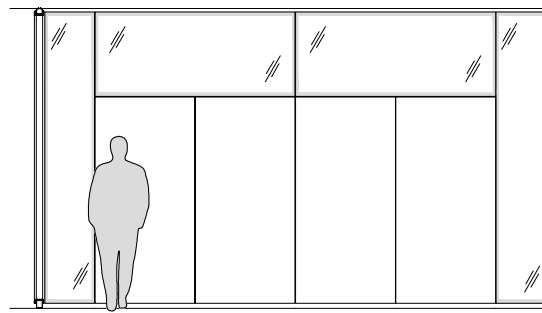

Glass element

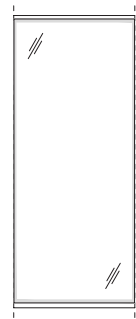

Clerestory element

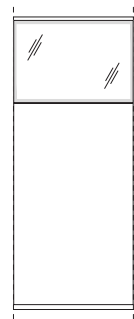

Balustrade element

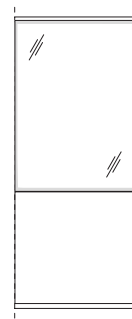

Acoustic absorber element with clerestory

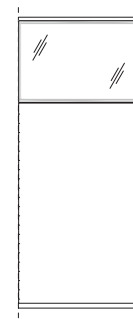

Clerestory element horizontal division

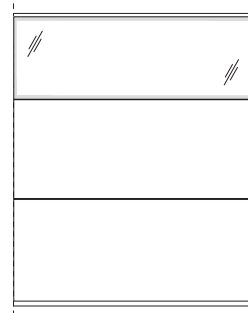

Clerestory element 2 modules

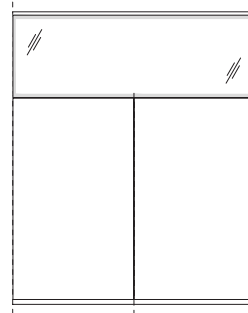

Flush bonded door ceiling-height



Flush bonded door with clerestory

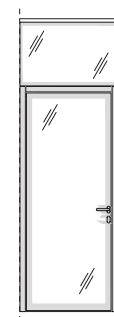

Flush bonded door with clerestory and side panel



Solid door with solid side and over panel

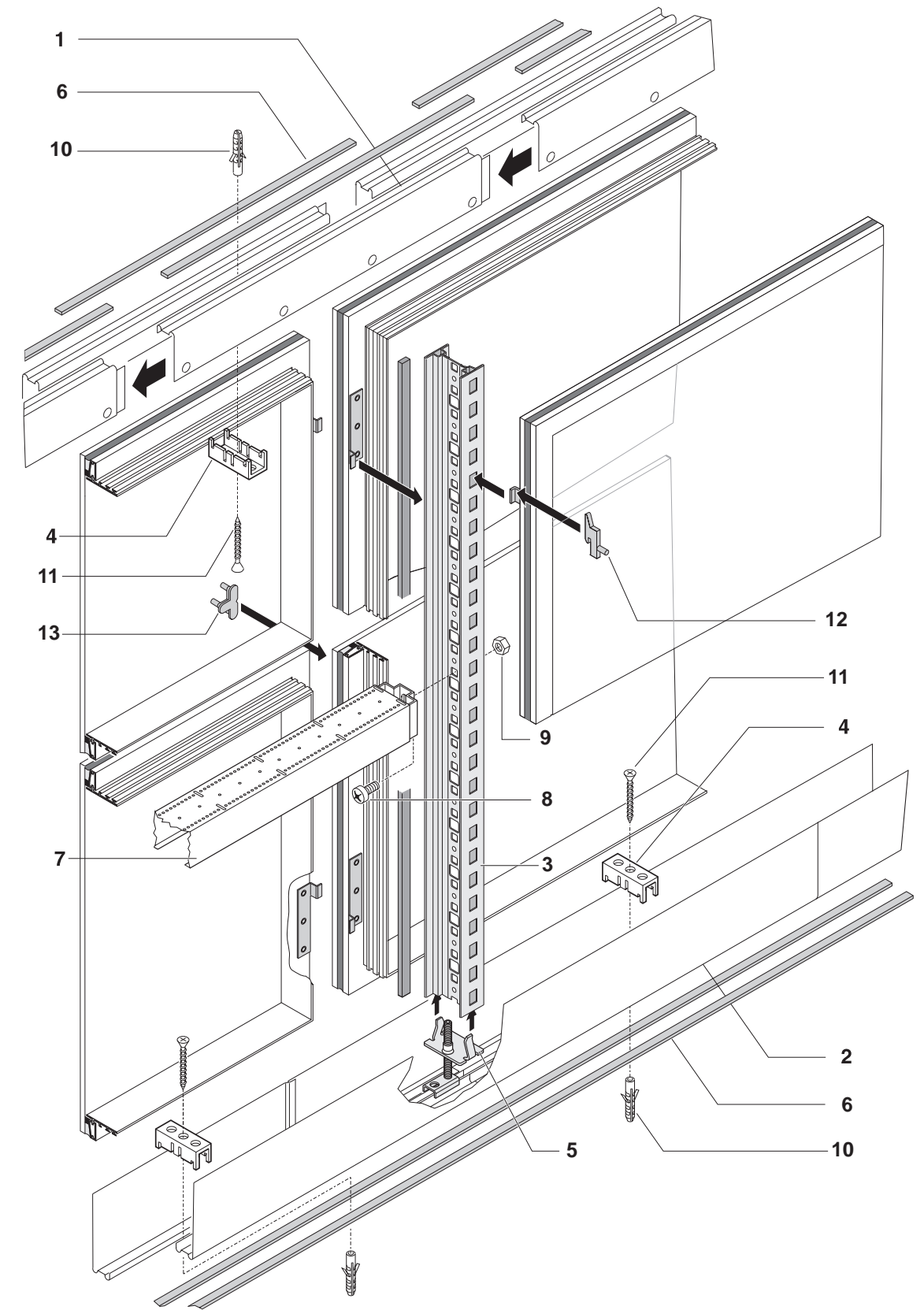
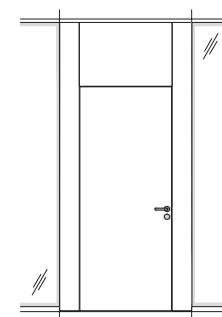

- | | | |
|---------------------------|-----------------------------|--------------------|
| 1 Ceiling L-profile | 6 Acoustic insulation strip | 11 Anchoring screw |
| 2 Floor L-profile | 7 Transom | 12 Hook bracket |
| 3 Steel mullion, RAL 7016 | 8 Bolt | 13 Spacer |
| 4 U-bracket | 9 Nut | |
| 5 Adjustable foot | 10 Plug | |

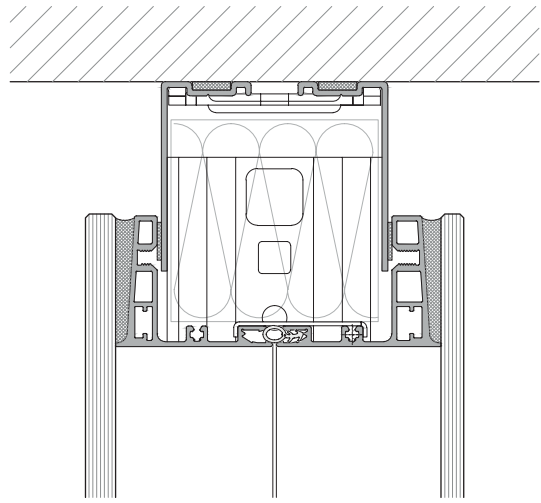

Clerestory ceiling connection

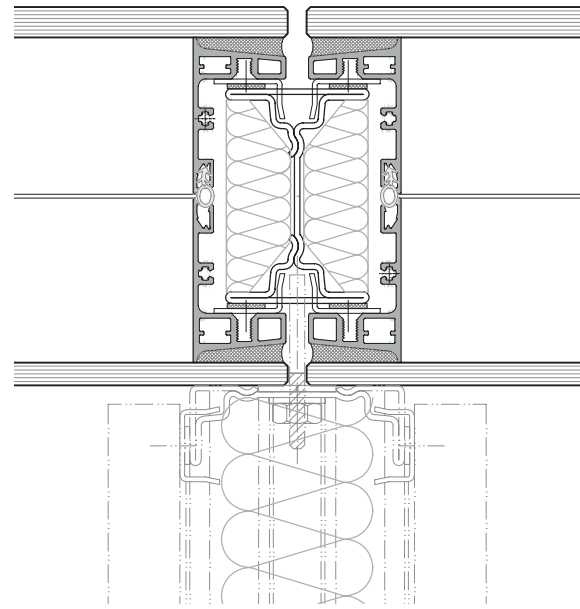

Glass wall T-junction

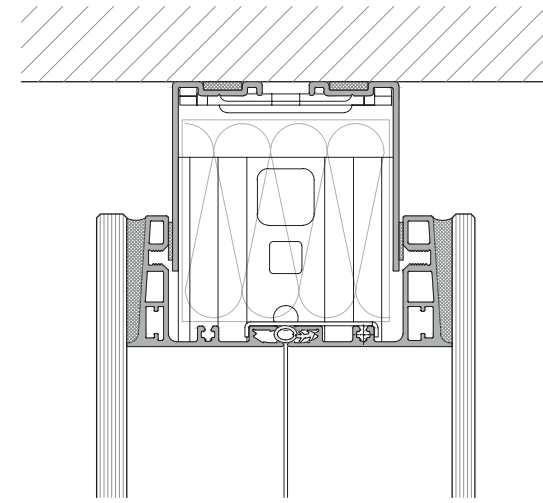

Flush glazing vertical section

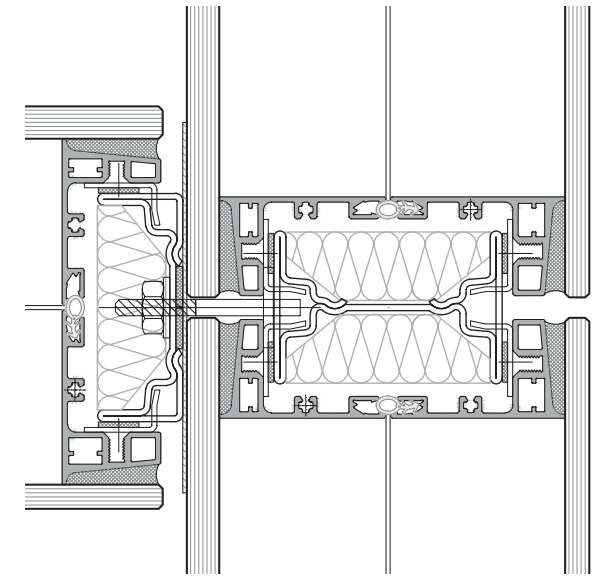

Flush glazing T-junction

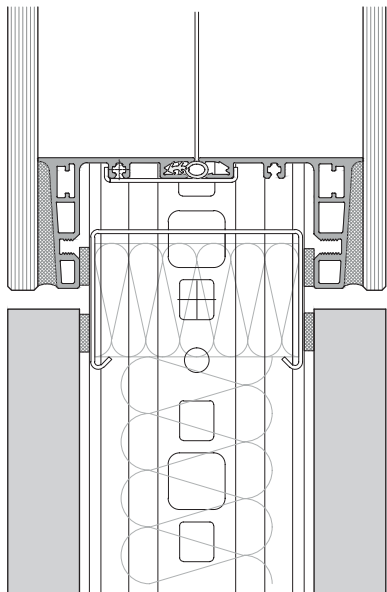

Solid wall horizontal joint

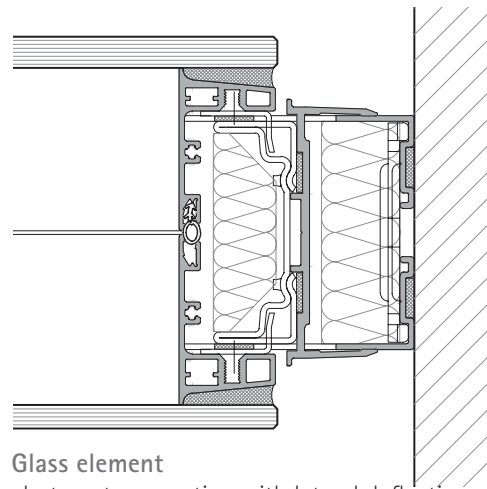

Glass element
abutment connection with lateral deflection

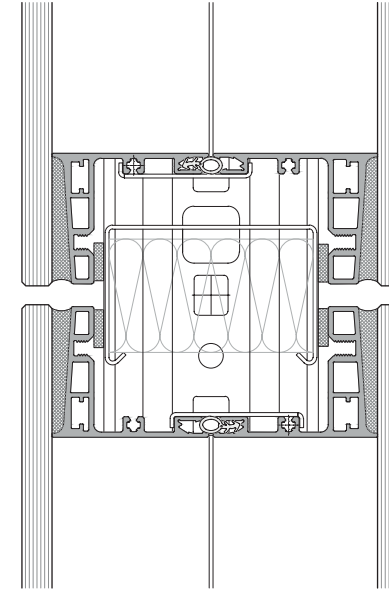

Flush glazing horizontal joint

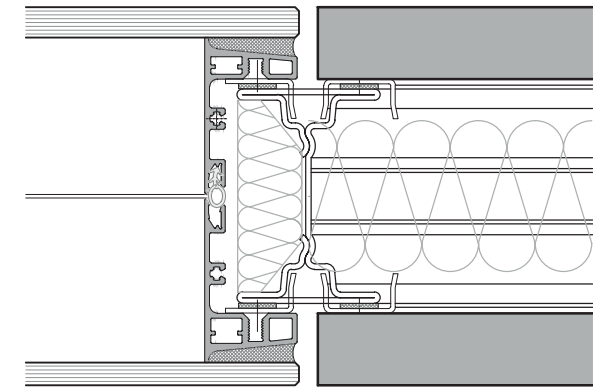

Flush glazing to solid straight connection

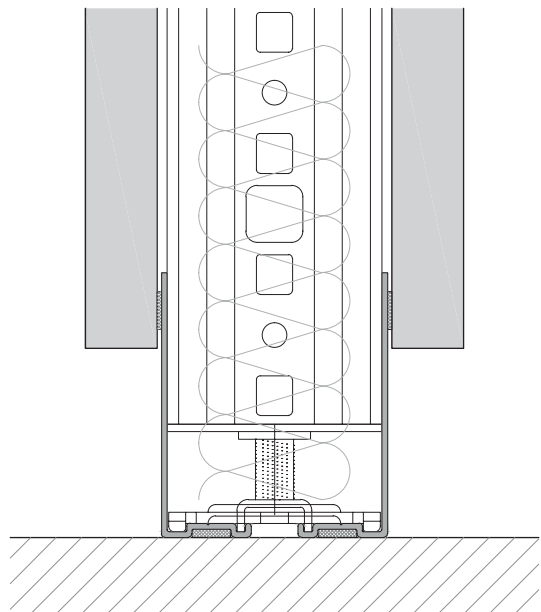

Solid wall floor connection

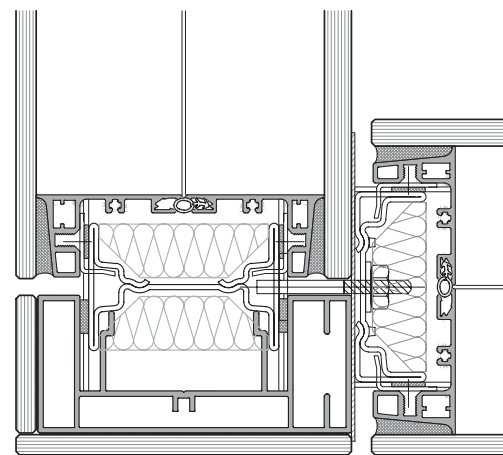

Glass wall 90° Corner element

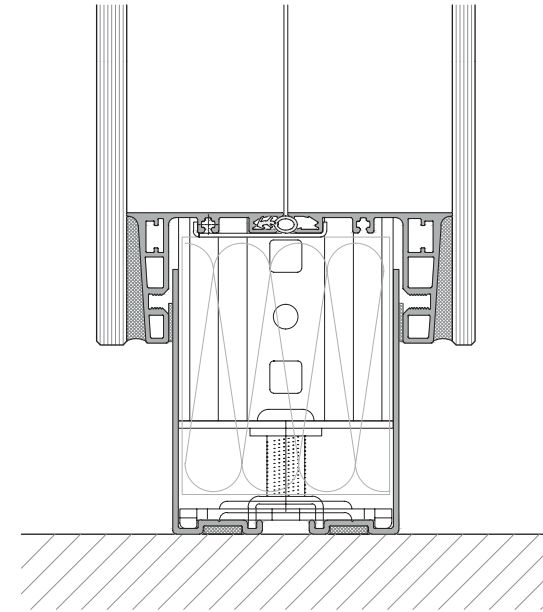

Flush glazing floor connection

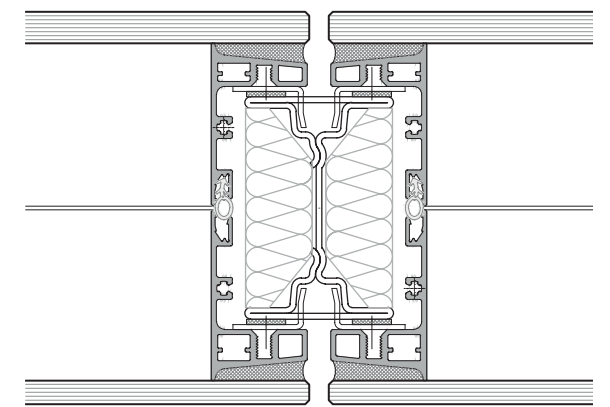

Flush glazing to flush glazed straight connection

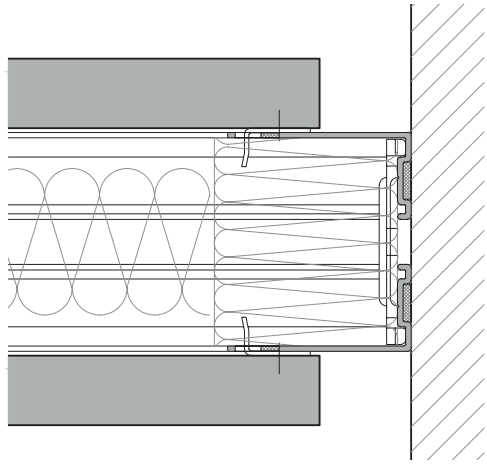

Solid wall abutment connection

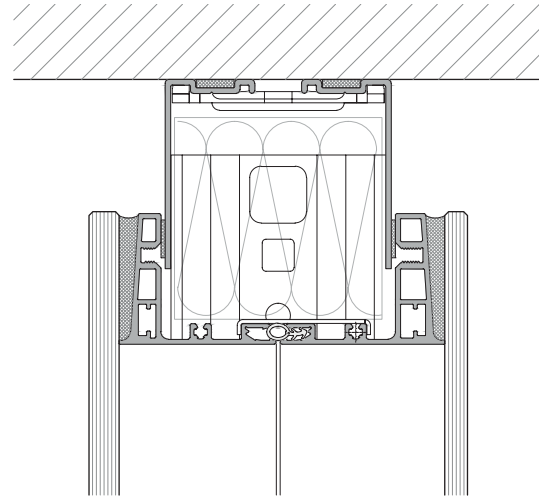

Flush glazing vertical section

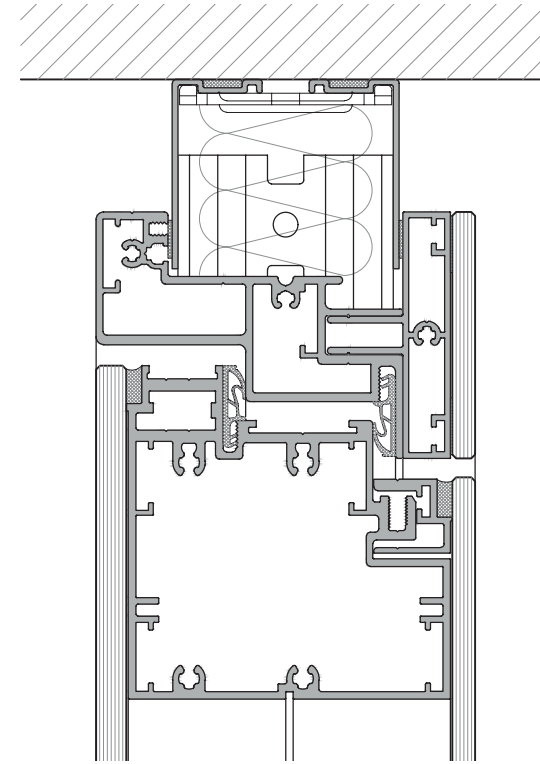

Flush bonded door toughened safety glass / acoustic laminated glass

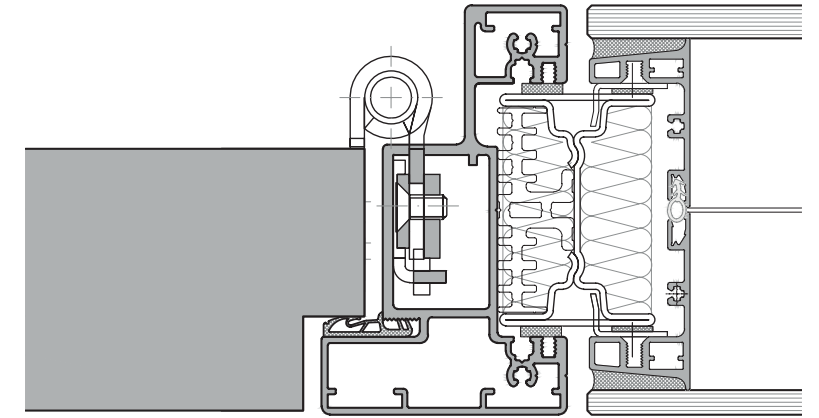

Solid door 64 mm

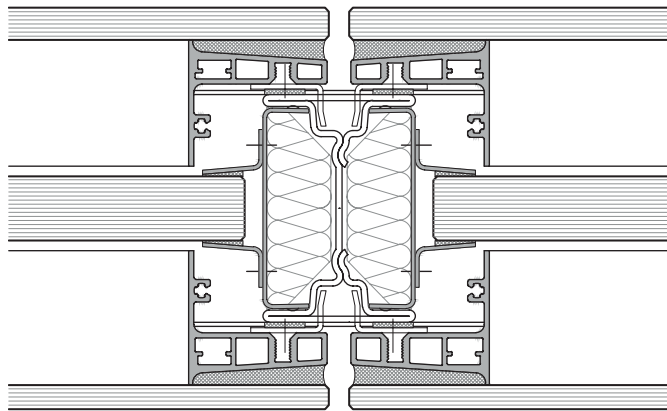

Solid wall abutment connection with lateral deflection

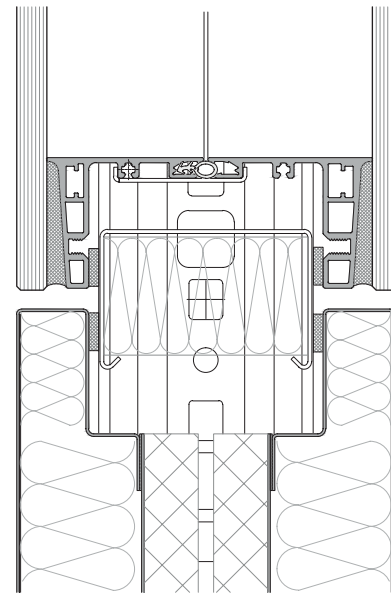

Flush glazing acoustic absorber for horizontal joint

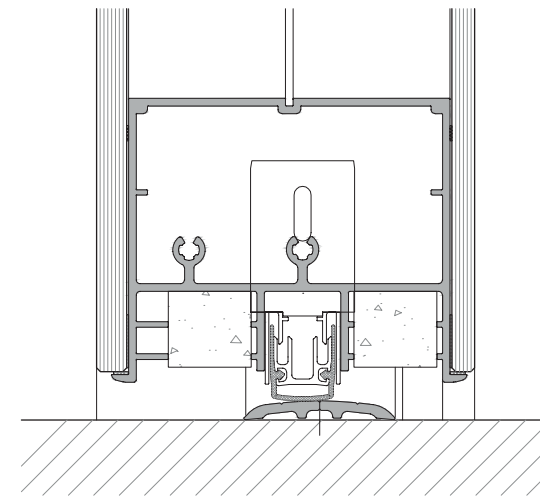

Flush bonded door 100 mm, toughened safety glass/ acoustic laminated glass

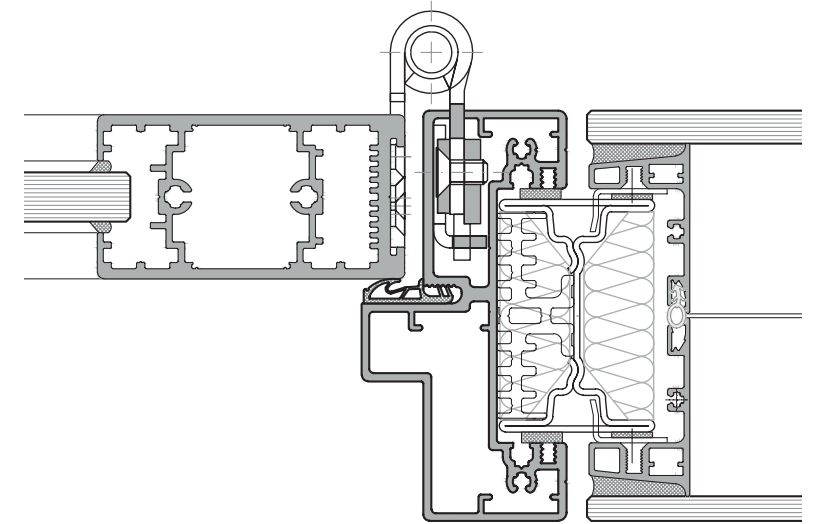

Flush bonded door toughened safety glass

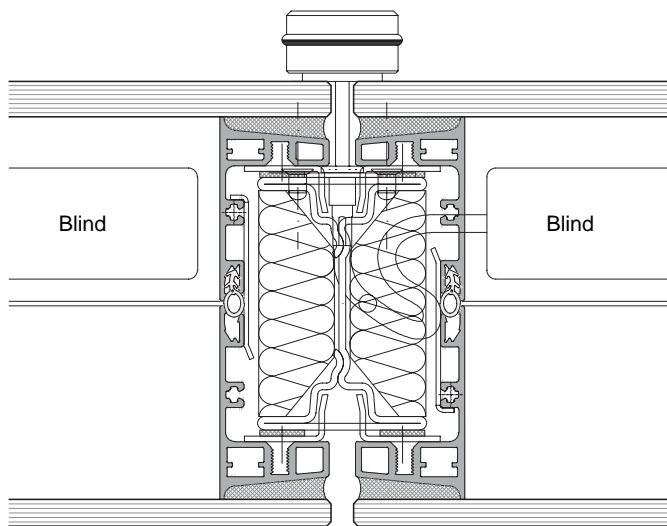

Flush glazing modular grid joint with blinds

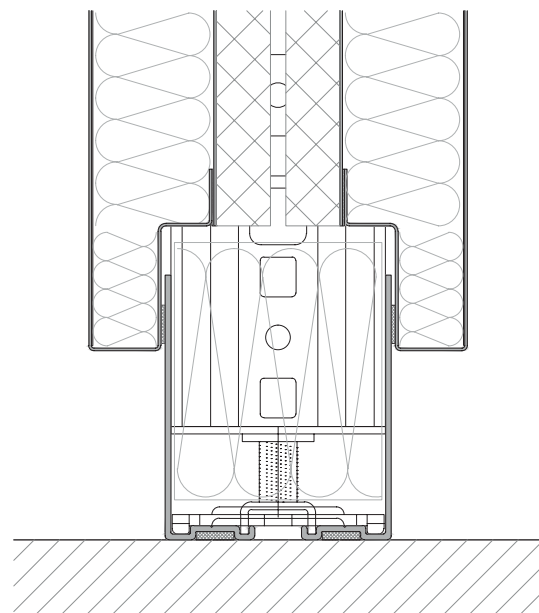

Floor connection acoustic absorber element

Partition wall	
Design	Modular and flexible partition wall system with panel design for walls and patented mullion structure. Panels and glazing elements are directly inserted into the mullion to form a structurally stable construction unit. The system is completed by high-quality aluminium door frames and door leaf options. The seamless glazed aesthetic of the partition wall is maintained with flush-bonded doors in both 64 mm and 100 mm thickness. Full compatibility with System 2000 is ensured by the same subconstruction.
Wall thickness	Standard version: 100, 125 mm
Grid	Dimensions as selected and according to structural strength approvals, preferred grid sizes: 1000, 1250, 1350, 1500 mm
Heights	Flexible construction height, for heights of 3,5 m and above or for large width modules, a 125 mm wall thickness is recommended
Substructure	Mullion, powder-coated RAL 7016 matt, with suspension system for accessory elements integrated as standard
Connecting section	Aluminium or steel sections, 20 mm set back from wall face
Deflection	Solid wall: +/- 15 mm, glass wall +/- 10 mm, telescopic connection possible for increased deflection
Skirting detail	50 mm and 80 mm standard heights, intermediate dimensions possible
Ceiling detail	35 mm standard, other dimensions and telescopic connections are possible
Finishes	- Continuous glass front with front flush bonding in light grey (black and white upon request) - Standard profiles: anodized aluminium E6EV1, steel RAL 9016, 7016 - Melamine coated chipboards, white similar to RAL 9016, light grey similar to RAL 7035 - Veneered, lacquered or fabric-upholstered boards - Powder-coated or fabric-upholstered metal panels
Glazing	- Flush-bonded glazing, 25 mm vertical aluminium frame and 35 mm horizontal aluminium frame. Available as fully-glazed, balustrade or clerestory versions.
Installation	- Vertical and horizontal cabling facility in the wall system - Switches, sockets and control elements can be integrated into the solid walls / door side panels
Accessories	
Acoustic absorbers	Flush-fitted, high-absorption and sound-insulating acoustics absorbers available in metal or wood
Accessory elements	- Vertical accessory elements integrated as standard in the standard version - Flush-mounted, horizontal accessory rail can be integrated into the wall panels
Blinds	Electrical and mechanical blinds can be integrated
Climate acoustic elements	Strähle ÜS 60 air-flow element available for integration into door side panel or high level panels
Door elements	
Door frames	Aluminium door frames with high-quality 3D hinges are available for receiving a variety of door options
Door leaves	Solid door: 41, 64, 78 and 100 mm Aluminium framed door: 40, 64 and 100 mm Flush bonded door: 100 mm Fully-glazed door: 10 mm
Sliding Doors	Floor and ceiling-guided options available

Wall element	Construction / Description	Wall element Sound insulation in R _{w,P}		Fire prevention	
		100 mm	125 mm	100 mm	125 mm
Solid wall	19 mm melamine / gap 60 mm / 19 mm melamine	45 dB	49 dB	45 dB	49 dB
	Add.1x plasterboard panel for enhanced acoustic performance	49 dB	52 dB	49 dB	52 dB
	Add. 2x plasterboard panel for enhanced acoustic performance	53 dB*	55 dB*	53 dB	55 dB
	Non-flammable material metal panel 2x plasterboard panels	51 dB	56 dB	-	-
	Special wall as dual mullion wall, cons. depth 160 mm		57 dB (max.)	-	-
Flush bonded glazing	Toughened safety glass / Float 5 + 6 mm	42 dB	44 dB	44 dB zus. F30 Glas	48 dB zus. F30 Glas
	Toughened safety glass / Float 6 + 8 mm	47 dB	47 dB	47 dB* zus. F30 Glas	49 dB zus. F30 Glas
	Toughened safety glass / Float 6 + Acoustic laminated glass 8 mm	49 dB*	51 dB	46 dB zus. F30 Glas	51 dB zus. F30 Glas
	Toughened safety glass / Float 8 + Acoustic laminated glass 8 mm	50 dB*	52 dB	48 dB* zus. F30 Glas	52 dB* zus. F30 Glas
	Acoustic laminated glass 8 mm + Acoustic laminated glass 8 mm	51 dB*	53 dB	49 dB* zus. F30 Glas	53 dB* zus. F30 Glas

* with seal + 1 dB possible

Door element	Construction / Description	Door element Sound insulation in R _{w,P}		2-leaved version
		100 mm wall	125 mm wall	
Solid door	Solid door leaf 41 mm	32 dB	32 dB	
	Sound-insulating door leaf 41 mm	38 dB	38 dB	
	Solid door leaf 64 mm	38 dB	38 dB	x
	Sound-insulating solid door leaf 64 mm in double-rebated frame	43 dB	43 dB	
	Sound-insulating solid door leaf 78 mm, concealed frame with double rebate	42/47 dB	42/47 dB	
	Sound-insulating solid door leaf 100 mm in double-rebated frame	42/47 dB	42/47 dB	x
Fully glazed door	Fully-glazed door 10 mm	32 dB	32 dB	
Aluminium framed door	Aluminium framed door 40 mm; 8 mm toughened safety glass, 8 mm acoustic laminated glass, 12 mm acoustic laminated glass	32, 34, 37 dB	32, 34, 37 dB	x
	Aluminium framed door 64 mm - 38 mm double glazed	37 dB	37 dB	x
	Aluminium framed door 100 mm 6 / 8 mm toughened safety glass	42 dB	42 dB	x
	Aluminium framed door 100 mm 6 mm toughened safety glass, 8 mm acoustic laminated glass	44 dB	44 dB	
	Aluminium framed door 100 mm 8 mm acoustic laminated glass, 8 mm acoustic laminated glass	46 dB	46 dB	
Structural Glazing door Sliding door	Flushed bonded door 100 mm 6 / 8 mm toughened safety glass	42 dB	42 dB	x
	ST40 Sound insulation sliding door	34 dB	34 dB	
Fireproof door	Solid door leaf certified based on German standards (Information available upon request)	37 dB	-	
	EI30 (CE standard) Flushed bonded door 100 mm ¹ glazing 6 mm toughened safety glass, EI30 BS glass, 8 mm toughened safety glass	43 dB	-	x
	EI30 (CE standard) Flushed bonded door 100 mm ¹ glazing 6 mm toughened safety glass, EI30 BS glass, 8 mm acoustic laminated glass	47 dB	-	x

Adjustment for calculation of arithmetic value of R_{wR} according to DIN 4109 is -2 dB for partition wall, -5 dB for door elements

The amount to be deducted for door elements of height 2.5 to 3.0 m is -2 dB, 2 leaved version -2 dB

* with seal +1 dB possible

Strähle Raum-Systeme GmbH
www.straehle.de
info@straehle.de

Gewerbestraße 6
71332 Waiblingen
T +49 7151 1714-0
F +49 7151 1714-320

Wurzelweg 5
14822 Borkheide
T +49 33845 66-0
F +49 33845 66-199

Austria
Industriestraße 9
2353 Guntramsdorf
T +43 2236 23232-0

Switzerland
Dellenbodenweg 1
4452 Itingen
T +41 61 463 1332
F +41 61 463 1333

UNITED KINGDOM PARTNER
Savile Row Projects Ltd
108-114 Golden Lane
EC1Y 0TG London
M +44 (0) 7813 652015